

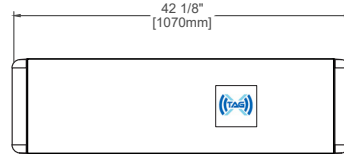

TAG-X Smart Rail

Smart Charging Rail



**Single Charger Unit
(Horizontal or Vertical)**

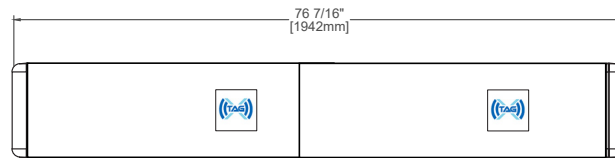
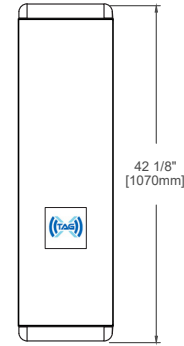

**Double Charger Unit
(Horizontal Only)**

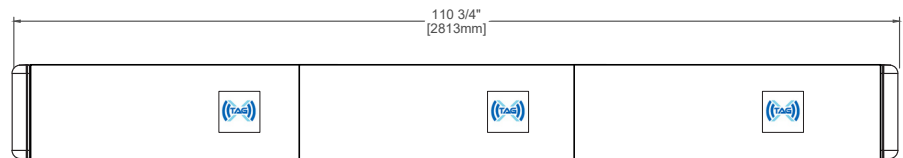

**Triple Charger Unit
(Horizontal Only)**

Product Details

- Mounted on a sturdy .080" (2mm) thick, continuous aluminum retainer
- .080" (2mm) thick, scratch and stain resistant rigid vinyl cover
- Easy installation, clean-up and maintenance
- Manufactured in 42" (1.06m) standard modules.
- Modular design allows system to stack meeting any wall condition or length.
- Can be oriented vertically for areas with limited wall space, or horizontally along a wall.
- All mounting fasteners are included with each order.
- Patented wireless charging technology allows for increased safety, simplified workflows, and effortless charges.

Options

- Cover and End caps are available in Inpro's White Sand

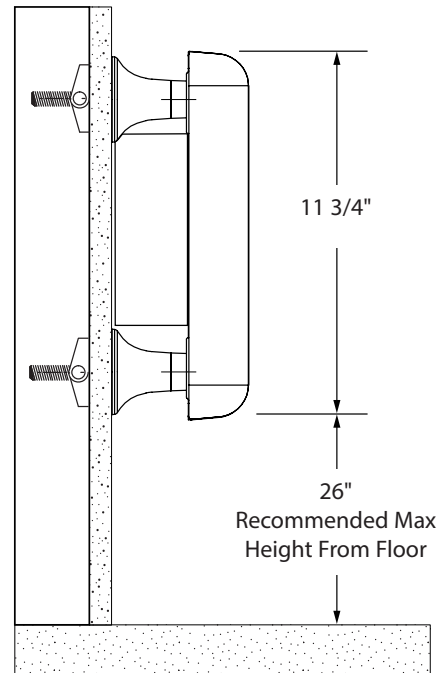

ISO.4020/REV1

O: (800) 285-2300 • TAGCarts.com • MyTAG@TAGCarts.com



TAG-X Smart Rail

Smart Charging Rail



General Component Layout Diagram

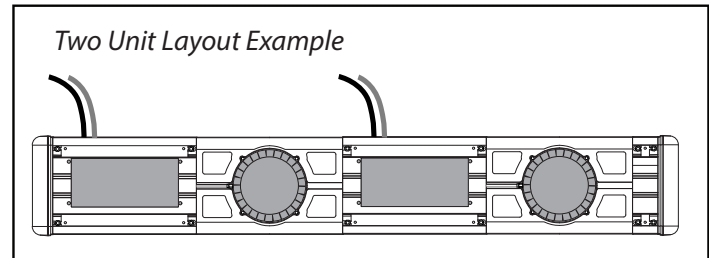
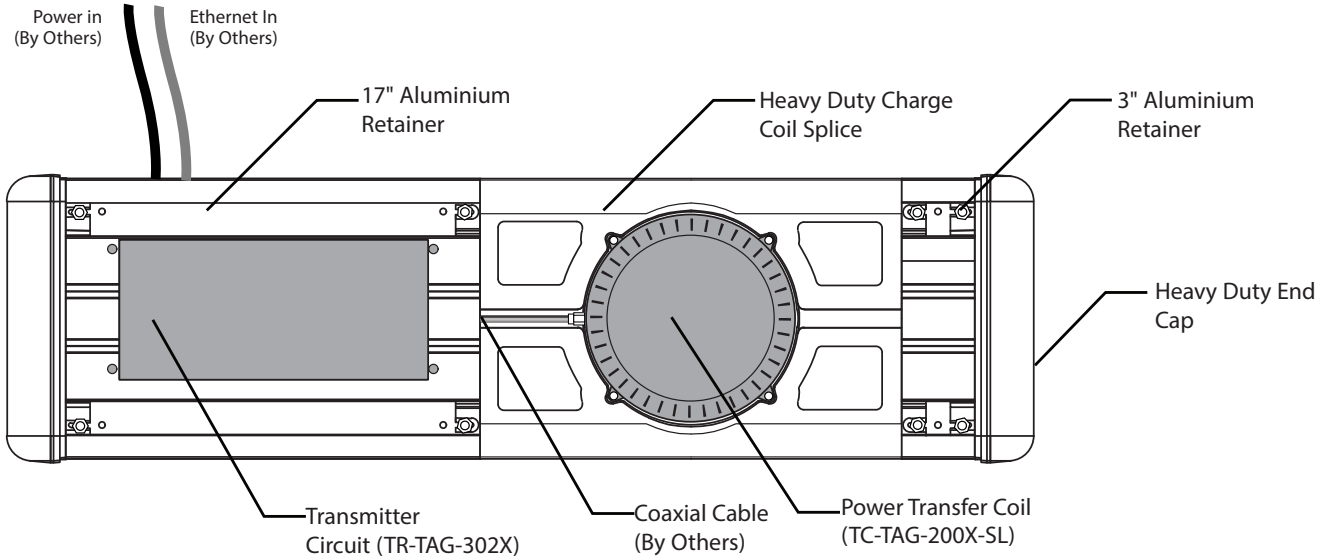

Detail Drawing Views

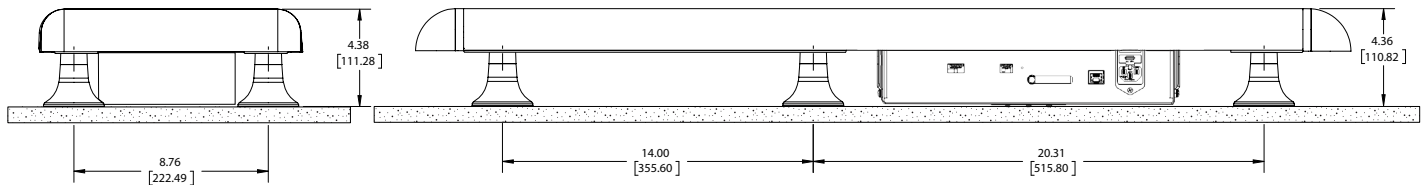

O: (800) 285-2300 • TAGCarts.com • MyTAG@TAGCarts.com